

# HINO 258<sub>LP</sub>

4 x 2 CONVENTIONAL

GVW: 25,500 lbs.

BBC: 108"

ENGINE MODEL: J08E-TV (Turbo Intercooled)

## DIMENSIONS (On standard specification)

Wheelbase/code A in.	175.0/J	187.0/L	205.0/M	212.0/N	217.0/P	235.0/R	253.0/T	271.0/V
Overall length B in.	278.6	302.6	320.6	354.6	354.6	372.6	390.6	390.6
Overall width C in.	95.7	95.7	95.7	95.7	95.7	95.7	95.7	95.7
Overall height D in.	102.6	102.6	102.6	102.6	102.6	102.6	102.6	102.6
Cab to axle E in.	107.6	119.6	137.6	144.6	149.6	167.6	185.6	203.6
Rear overhang F in.	63.0	75.0	75.0	102.0	97.0	97.0	97.0	79.0
Frame height at:								
Front axle G in.	32.7	32.7	32.7	32.7	32.7	32.7	32.7	32.7
Rear axle H in.	35.6	35.6	35.6	35.6	35.6	35.6	35.6	35.6
Road clearance (at diff. axle) J in.	7.1	7.1	7.1	7.1	7.1	7.1	7.1	7.1
Tread:								
Front K in.	79.5	79.5	79.5	79.5	79.5	79.5	79.5	79.5
Rear L in.	72.6	72.6	72.6	72.6	72.6	72.6	72.6	72.6
Turning radius:								
Tire ft.	48.0	51.0	55.4	57.0	58.4	62.6	67.0	71.5
Wall to wall ft.	51.4	54.2	58.6	60.3	61.6	66.0	70.4	74.8

## CHASSIS WEIGHTS (On standard specification)

AT	Total weight lb.	9,080	9,140	9,250	9,370	9,370	9,440	9,470	9,510
	Front axle lb.	5,815	5,855	5,955	5,985	5,985	6,065	6,110	6,190
	Rear axle lb.	3,265	3,285	3,295	3,385	3,385	3,375	3,360	3,320

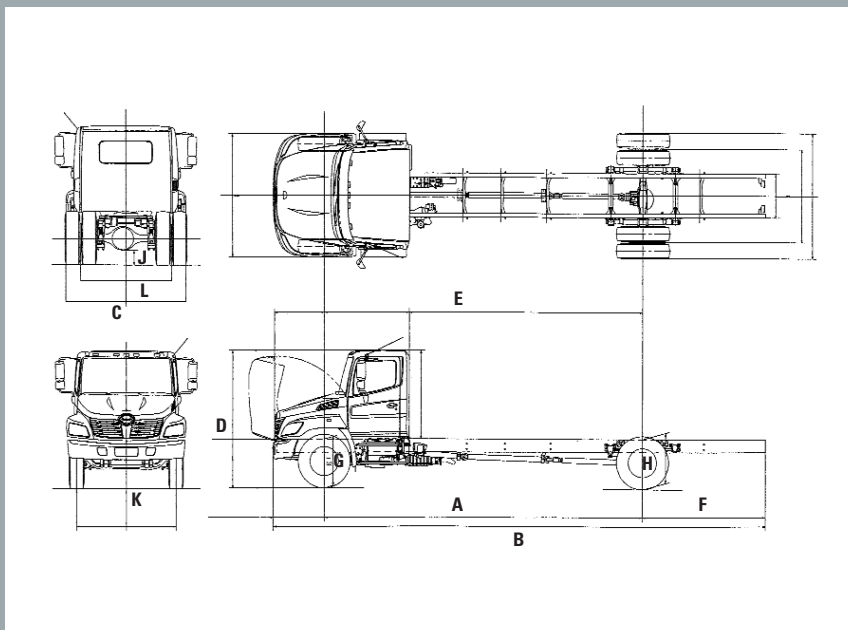

## ENGINE

MODEL	HINO J08E-TV
Type	Diesel 4-cycle, 6-cylinder in-line, water-cooled
Combustion system	Direct injection type
Max. output (SAE Gross)	220 hp at 2,500 rpm
Max. torque (SAE Gross)	520 lb.-ft. at 1,500 rpm
Bore and stroke	4.41 x 5.12 in.
Piston displacement	7.680 L
Fuel injection pump	Radial plunger (HP-4)
Governor	Electronically controlled
Intake system	Turbocharged and intercooled
Air cleaner	Paper filter type (DONALDSON)
Fan clutch	Bimetal thermostat sensor regulates fan speed
Glow plugs	Standard
Air compressor	Single cylinder, 6.8 cfm @ 1,250 rpm

## POWERTRAIN & PERFORMANCE

25,500 lbs. GVW & 245/70R19.5 tires		
Powertrain	<input type="checkbox"/> STD.	
Max. speed mph	84	
Startability (tan.θ) %	31.8	
Transmission	Model	Allison 2200 RDS
	Type	Five-speed automatic
Ratios	1st.	3.102
	2nd.	1.811
	3rd.	1.406
	4th.	1.000
	5th.	0.712
	6th.	—
	Rev.	4.492
Rear axle gear ratios	4.110	



# HINO 258LP

4 x 2 CONVENTIONAL

GVW: 25,500 lbs. BBC: 108"

ENGINE MODEL: J08E-TV (Turbo Intercooled)

## WEIGHT CAPACITIES

Front axle	lbs.	8,000
Rear axle	lbs.	17,500
Front spring	lbs.	8,000
Rear spring	lbs.	19,000

## LIQUID CAPACITIES

Fuel tank	gal./US	52
Cooling system	gal./US	6.08 : ALLISON 2200
Engine oil	qt./US	16.15

## AXLE / SUSPENSION

Front axle	MFS-8 series reversed Elliot, "I" beam, oil-lubricated
Front spring	Taper-leaf springs w/shock absorbers
Rear axle	RS17-145 series Full-floating, single reduction Single-speed by hypoid gearings with oil-lubricated type
Rear spring	Semi-elliptic main and auxiliary helper-leaf spring

## FRAME

Ladder type	Straight C Channel	
Width	in.	34
Yield strength	PSI	80,000
Resisting bending moment (one side)	in.-lbs.	1,031,900 no reinforcement

## STEERING

Type	TRW-TAS65 recirculating ball with tilt and telescopic steering column
------	---

## WHEELS / TIRES

6 Wheels	19.5 x 6.75 8-stud disc.
6 Tires	245/70R19.5 (G)
Pattern	Front rib / Rear lug

## BRAKES

Service brake	Hydraulic system with disc brake for front and rear wheels, with automatic adjustment
Disc diameter x pad area x thickness in.	Front: 15.375 x 18.96 x 0.74 Rear: 15.375 x 18.96 x 0.74
Control	Hydraulic dual circuit with Antilock Brake System (ABS)
Parking brake	Mechanical, internal expanding acting on transmission output shaft
Drum diameter in.	12 : MERITOR

## CAB EQUIPMENT

Cab construction	All steel welded
Seating	Three-person
Driver's seat	Adjustable reclining, vinyl with coil suspension
Passenger's seat	Bench type, vinyl (two passenger)
Seat belts	3-point type (driver and passenger), one 2-point type (center)
A/C	134 Denso
Heater/Defroster	18,357 BTU/h
Mirrors outside rearview	Four; one flat and one convex at each side
Sun visors	Two – flip-down
Overhead compartment	Two with latching doors
Chrome grille	Standard
Windshield	Laminated
Windshield wipers	Dual electric, 2-speed and intermittent
Cup holders	Standard
Cigarette lighter	Standard
Coat hook	One (rear panel)
Door pockets	Two
Cruise control	Standard

## DASH INSTRUMENTATION

Meters and gauges	Speedometer-mph (km/h) Odometer (mile) Fuel gauge Coolant temperature gauge Engine tachometer
Warning lamps and buzzers	Oil pressure warning lamp and buzzer Brake pressure warning lamp and buzzer Coolant level warning lamp and buzzer Battery charging system warning lamp High beam indicator lamp Turn signal indicator Parking brake warning lamp Engine control system warning lamp ABS warning lamp
Driver information display	Instant & trip fuel consumption DPR monitor Maintenance schedules Engine/vehicle diagnostics

## ELECTRICAL EQUIPMENT

Batteries	Two, parallel connection, each 12 V
Capacity	1200 CCA
Alternator	12 V, 100 A, brush Delco
Starter	12 V 2.5kw Denso
Audio	AM/FM radio with CD, two speaker
Headlamps	Integrated with turn signal and hazard lamps
Stop/Tail lamps	
Back-up lamps	
Side-flasher lamp	
Trucklite LED cab marker lamps	
Electric horn (dual)	

## CHASSIS EQUIPMENT

Fuel pre-filter	Davco 230 FuelPro® Heated fuel/water separator
Reflectors	Two rear, two front side
Tow hook	One at front
Air dryer	NABCO, heated
Air tank	49 L

## OPTIONS

Rear shock absorbers
Hendrickson air suspension*
Cold weather package (includes) Heated mirror Block heater
Front Bumper (three pieces)
Front Bumper (three pieces with 4 inch extension/black)
Front Bumper (4 inch extension / black)
Front Bumper (chrome)
Front Bumper (4 inch extension/chrome)
Alternator – 12 V, 105 A, brushless
Battery – 12 V GR31 x 2; GR31 x 3; GR27 x 3
Fuel tank – dual 52 gal./US; 95 gal./US
Tires – Front: rib, Rear: rib
Auto 2200 RDS trans. with PTO provision
Air horn
Exhaust system – Stack tail type; vertical stack
Electric over air dump valve
Cloth seats
Single passenger's seat – Adjustable reclining
Chrome mirrors – heated/non-heated
Exhaust brake – electric-pneumatic with valve in exhaust pipe
Synthetic fluids – transmission/rear differential
Cab paint – red or black
Safety kit (fire extinguisher and triangle kit)
Rear stabilizer
Power windows
Aluminum wheels

\* Wheelbase specific

## ROADSIDE ASSISTANCE

HinoWatch (service free of charge)	3-year unlimited roadside assistance • Lockout • Out of Fuel • Battery Jumpstart • Information • Warranty Towing
------------------------------------	---

## NOTE:

All specifications of the products are with normal manufacturing allowances and tolerances. HINO MOTORS SALES U.S.A., INC. reserves the right to alter specifications at any time without previous notice. Some optional items may require extra lead time.