

HINO 145

4 x 2 CONVENTIONAL

GVW: 14,050 lbs.

BBC: 98"

Engine Model: J05D-TF (Turbo Intercooled)

2009 SPECIFICATIONS

DIMENSIONS (On standard specification)					
Wheelbase/Code	A in.	147.0/F	169.0/J	183.0/K	201.0/M
Overall length	B in.	244.6	266.6	292.6	310.6
Overall width	C in.	89.6	89.6	89.6	89.6
Overall height	D in.	100.4	100.4	100.4	100.4
Cab to axle	E in.	83.6	105.6	119.6	137.6
Rear overhang	F in.	63.0	63.0	75.0	75.0
Frame height at:					
Front axle	G in.	29.1	29.1	29.1	29.1
Rear axle	H in.	33.1	33.1	33.1	33.1
Road clearance (at front axle)	J in.	6.3	6.3	6.3	6.3
Tread:					
Front	K in.	73.6	73.6	73.6	73.6
Rear	L in.	71.1	71.1	71.1	71.1
Turning radius:					
Tire	ft.	40.6	46	49.4	53.8
Wall to wall	ft.	43.6	49	52.4	56.8

CHASSIS WEIGHTS (On standard specification)						
	Total weight	lb.	6,790	6,880	6,930	6,980
AT	Front axle	lb.	4,530	4,620	4,670	4,720
	Rear axle	lb.	2,260	2,260	2,260	2,260

ENGINE

Model	HINO J05D-TF
Type	Diesel 4-cy., 4-cyl. in-line, water-cooled
Combustion system	Direct injection type
Max. output (SAE Gross)	175HP at 2,500 rpm
Max. torque (SAE Gross)	376 lb.-ft. at 1,600 rpm
Bore and stroke	4.41 x 4.72 in.
Piston displacement	4.730L
Fuel injection pump	Radial plunger pump (HP-3)
Governor	Electronically controlled
Intake system	Turbocharged and intercooled
Air cleaner	Paper filter type (Donaldson)
Fan clutch	Bimetal thermo-stat sensor regulates fan speed
Glow plugs	Standard
Air compressor	Single cylinder, 6.8 cfm @ 1,250 rpm

POWERTRAIN AND PERFORMANCE

14,050 lbs. GVW and 215-85R16 tires

Max. speed mph	78	
Startability (tan.θ) %	57.6	
Transmission	Model	Aisin 450-43LE
	Type	Four-speed automatic
Ratios	1st.	3.018
	2nd.	1.548
	3rd.	1.000
	4th.	0.703
	5th.	-
	Rev.	2.678
Rear axle gear ratios	4.780	

ROADSIDE ASSISTANCE

HinoWatch (service free of charge)	3-year unlimited roadside assistance
	<ul style="list-style-type: none"> • Lockout • Out of Fuel • Battery Jumpstart • Information • Warranty Towing

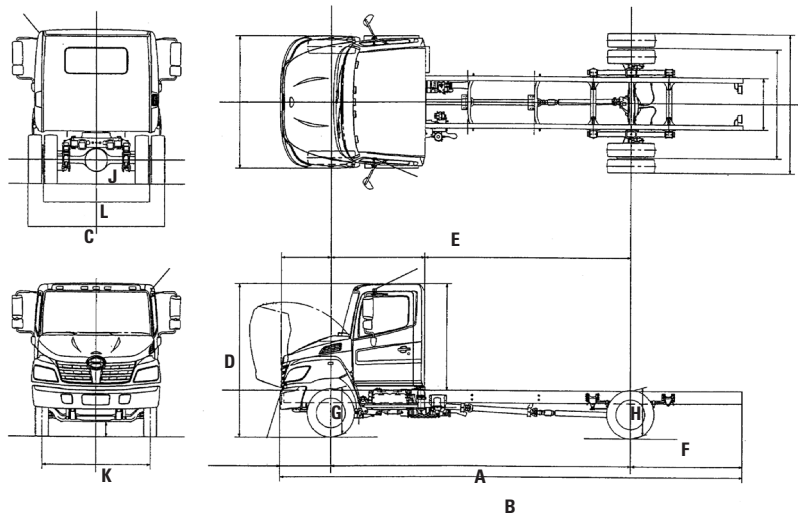

HINO TRUCKS
A Toyota Group Company

Visit Us At WWW.HINO.COM

WEIGHT CAPACITIES

Front axle	lbs.	5,360
Rear axle	lbs.	9,880
Front spring	lbs.	6,000
Rear spring	lbs.	11,000

LIQUID CAPACITIES

Fuel tank	gal.	35
Cooling system	gal.	5.16
Engine oil	qt.	10.73

AXLE/SUSPENSION

Front axle	MFS6 series reversed Elliot, "1" beam
Front spring	Taper-leaf springs shock absorbers
Rear axle	MS113 series Full-floating, single reduction Single-speed by hypoid gearings
Rear spring	Semi-elliptic main and auxiliary helper-leaf spring

FRAME

Ladder type		Straight C Channel
Width	in.	34
Yield strength	PSI	80,000
Resisting bending moment (one side)	in.-lbs.	655,100 no reinforcement

STEERING

Steering column adjustability	Tilt and telescopic with lock
Steering system	TRW recirculating ball, with hydraulic booster, integral type

WHEELS/TIRES

6 Wheels	16 x 6k 6-stud disc.
Wheel style	Steel, painted
6 Tires	215/85R16
Tire brand and pattern	Bridgestone Fr-rib Rr-lug type

BRAKES

Service brake	Hydraulic system with disc brake for front and rear wheels, with automatic adjustment
Disc diameter x pad area x thickness (in.)	Front; 11.97 x 17.05 x 0.61 Rear; 11.97 x 17.05 x 0.61
Control	Hydraulic dual circuit with Antilock Brake System(ABS)
Parking brake	Mechanical, internal expanding acting on transmission output shaft
Drum diameter (in.)	10 : Meritor
Exhaust brake	Electric-pneumatic with valve in exhaust pipe

CAB EQUIPMENT

Cab construction	All steel welded
Seating capacity	Three
Driver's seat	Adjustable reclining, covered with vinyl with coil suspension
Passenger's seat	Bench type, covered with vinyl
Seat belts	3-point type (driver and passenger), one 2-point type (center)
Air conditioning	Standard
Heater/Defroster	18,357 BTU/h
Mirrors, outside rearview	Four, 1-flat and 1-convex at each side
Sun visors	Two
Over-head consoles	Two
Ventilator	Electric forced air
Windshield	Laminated
Windshield wipers	Dual electric, 2-speed and intermittent
Cup holders	Two at center cluster
Cigarette lighter	Equipped
Speakers	Two for front
Coat hook	One (rear panel)
Door pockets	Two
Cruise control	Standard

DASH INSTRUMENTATION

Meters and gauges ft. lb. system
Speedometer-mph (km/h)
Odometer (mile)
Fuel gauge
Coolant temperature gauge
Engine tachometer
Warning and pilot lamps and buzzers
Oil pressure warning lamp and buzzer
Brake pressure warning lamp and buzzer
Coolant level warning lamp and buzzer
Battery charging warning lamp
High beam indicator lamp
Turn signal pilot lamp
Parking brake warning lamp
Engine control system warning lamp
ABS warning lamp
Driver Information Display
Instant and trip fuel consumption
DPR monitor
Maintenance
Engine/vehicle diagnostics

ELECTRICAL EQUIPMENT

Batteries	Two, parallel connection, each 12 V
Capacity	1200 CCA
Alternator	12 V, 100 A, brush Delco
Starter	12 V, 2.5 kW Denso
Car audio	AM/FM radio with CD
Headlamps	Daylight running - integrated with turn signal and hazard lamps
Identification lamps (front)	
Stop/Tail lamps	
Back-up lamps	
Side-flasher lamp	
Front side marker lamps	
Trucklite LED marker lamps (front)	
Electric horn (dual)	

CHASSIS EQUIPMENT

Radiator grille	Chrome
Fuel tank	Aluminum
Fuel pre-filter	Pre-filter (dust) and sediment (water)
Reflectors	Two rear, two front side
Tow hook	One at front
Air dryer	NABCO, heated
Air tank	49L

CAB CONFIGURATION OPTIONS

Extended cab	30" cab extension, available with full-width bench seat or 26" day bunk
--------------	---

OPTIONAL EQUIPMENT

Alternator - 12 V, 105 A, brushless
Battery - Three parallel connection each 12 V (80 AH)
Bumper, front - Black and 4 inch extension
Bumper, front - White and 4 inch extension
Bumper, front - Chrome and 4 inch extension
Bumper, front - Chrome (available with one or two tow hooks)
Cold weather package - Heated mirrors (available in chrome) - Engine block heater
Engine block heater
Mirrors, outside rearview - Heated with marker light
Mirrors, outside rearview - Chrome
Mirrors, outside rearview - Chrome, heated with marker light
Power windows and power door locks
Seat - Driver's seat with air suspension
Seats - Vinyl with reclining single person passenger seat
Seats - Fabric with reclining single person passenger seat
Seats - Fabric with two person bench seat
Seating capacity - Two or three person
Shock absorbers, rear
Stabilizer, front - With shock absorber
Tire pattern - Rib on rear
Tow Hooks - Two at front
Engine idle throttle knob - Removed
Exhaust brake - Disengage

NOTE:

All specifications of the products are with normal manufacturing allowances and tolerances. HINO MOTORS SALES U.S.A., INC. reserves the right to alter specifications at any time without previous notice. Some optional items of equipment may require extra time due to the need for their adaptation on the product line.