

2010

SPECIFICATIONS

HINO 145

4 x 2 Conventional GVW: 14,050 lbs. BBC: 98" Engine Model: J05D-TF (Turbo Intercooled)

DIMENSIONS (On standard specification)

Wheelbase/Code	A in.	147.0/F	169.0/J	183.0/K	201.0/M
Overall length	B in.	244.6	266.6	292.6	310.6
Overall width	C in.	89.6	89.6	89.6	89.6
Overall height	D in.	100.4	100.4	100.4	100.4
Cab to axle	E in.	83.6	105.6	119.6	137.6
Rear overhang	F in.	63.0	63.0	75.0	75.0
Frame height at:	Front axle	G in.	29.1	29.1	29.1
	Rear axle	H in.	33.1	33.1	33.1
Road clearance (at front axle)	J in.	6.3	6.3	6.3	6.3
Tread:	Front	K in.	73.6	73.6	73.6
	Rear	L in.	71.1	71.1	71.1
Turning radius:	Curb to curb	ft.	40.6	46.1	49.5
	Wall to wall	ft.	43.6	49	52.4

CHASSIS WEIGHTS (On standard specification)

AT	Total weight	lb.	6,720	6,820	6,880	6,910
	Front axle	lb.	4,470	4,570	4,630	4,660
	Rear axle	lb.	2,250	2,250	2,250	2,250

ENGINE

Model	HINO J05D-TF
Type	Diesel 4-cycle, 4-cylinder in-line water-cooled, dry cylinder line
Combustion system	Direct injection type
Max. output (SAE Gross)	175HP at 2,500 rpm
Max. torque (SAE Gross)	376 lb.-ft. at 1,600 rpm
Bore and stroke	4.41 x 4.72 in.
Piston displacement	4.730L
Fuel injection pump	Radial plunger pump (HP-3)
Governor	Electronically controlled
Intake system	Turbocharged and intercooled
Air cleaner	Paper filter type (Donaldson)
Fan clutch	Bimetal thermo-stat sensor regulates fan speed
Glow plugs	Standard
Air compressor	Single cylinder, 6.8 cfm @ 1,250 rpm

POWERTRAIN AND PERFORMANCE

14,050 lbs. GVW and 215-85R16 tires		
Max. speed mph	78	
Startability (tan.θ) %	57.6	
Transmission	Model	Aisin 450-43LE
	Type	Four-speed automatic
Ratios	1st.	3.018
	2nd.	1.548
	3rd.	1.000
	4th.	0.703
	5th.	-
	Rev.	2.678
Rear axle gear ratios	4.780	

ROADSIDE ASSISTANCE

HinoWatch (service free of charge)	3-year unlimited roadside assistance
	• Lockout
	• Out of Fuel
	• Battery Jumpstart
	• Information
	• Warranty Towing (2 year coverage)

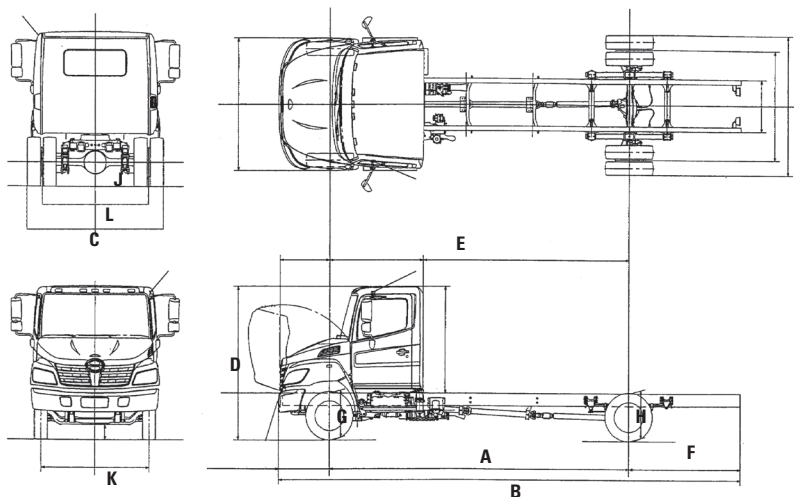

Ranks "Highest in Customer Satisfaction Among Conventional Medium Duty Trucks"

For J.D. Power and Associates award information, visit jdpower.com.

WEIGHT CAPACITIES

Front axle	lbs.	5,360
Rear axle	lbs.	9,880
Front spring	lbs.	6,000
Rear spring	lbs.	11,000

LIQUID CAPACITIES

Fuel tank	gal.	35
Cooling system	gal.	5.16
Engine oil	qt.	10.73

AXLE/SUSPENSION

Front axle	MFS6 series reversed Elliot, "1" beam (oil lubricated type)
Front spring	Taper-leaf springs shock absorbers
Rear axle	MS113 series Full-floating, single reduction Single-speed by hypoid gearings
Rear spring	Semi-elliptic main and auxiliary helper-leaf spring

FRAME

Ladder type	Straight C Channel	
Width	in.	34
Yield strength	PSI	80,000
Resisting bending moment (one side)	in-lbs.	655,100 no reinforcement

STEERING

Steering column	Tilt and telescopic with lock adjustability
Steering system	TRW recirculating ball, with hydraulic booster, integral type

WHEELS/TIRES

6 Wheels	16 x 6k 6-stud disc.
Wheel style	Steel, painted
6 Tires	215/85R16
Tire brand and pattern	Bridgestone Fr-rib Rr-lug type

BRAKES

Service brake	Hydraulic system with disc brake for front and rear wheels, with automatic adjustment
Disc diameter x pad area x thickness (in.)	Front; 11.97 x 17.05 x 0.61 Rear; 11.97 x 17.05 x 0.61
Control	Hydraulic dual circuit with Antilock Brake System(ABS)
Parking brake	Mechanical, internal expanding acting on transmission output shaft
Parking brake drum diameter (in.)	10 : Meritor
Exhaust brake	Electric-pneumatic with valve in exhaust pipe

CAB EQUIPMENT

Air conditioning	Standard
Cab construction	All steel welded
Cigarette lighter	Equipped
Coat hook	One (rear panel)
Cruise control	Standard
Cup holders	Two at center cluster
Door pockets	Two
Driver's seat	Adjustable reclining, covered with vinyl with coil suspension
Heater/Defroster	18,357 BTU/h
Mirrors, outside rearview	Four, 1-flat and 1-convex at each side
Over-head consoles	Two
Passenger's seat	Bench type, covered with vinyl
Seat belts	3-point type (driver and passenger), one 2-point type (center)
Seating capacity	Three
Speakers	Two for front
Sun visors	Two
Ventilator	Electric forced air
Windshield	Laminated
Windshield wipers	Dual electric, 2-speed and intermittent

DASH INSTRUMENTATION

Meters and gauges ft. lb. system
Speedometer-mph (km/h)
Odometer (mile)
Fuel gauge
Coolant temperature gauge
Engine tachometer
Warning and pilot lamps and buzzers
Oil pressure warning lamp and buzzer
Brake pressure warning lamp and buzzer
Coolant level warning lamp and buzzer
Battery charging warning lamp
High beam indicator lamp
Turn signal pilot lamp
Parking brake warning lamp
Engine control system warning lamp
ABS warning lamp
Driver Information Display
Instant and trip fuel consumption
DPR monitor
Maintenance
Engine/vehicle diagnostics

ELECTRICAL EQUIPMENT

Batteries	Two, parallel connection, each 12 V
Capacity	1200 CCA
Alternator	12 V, 100 A, brush Delco
Starter	12 V, 2.5 kW Denso
Car audio	AM/FM radio with CD
Headlamps	Daytime running - integrated with turn signal and hazard lamps
Stop/Tail lamps	
Back-up lamps	
Side-flasher lamp	
Front side marker lamps	
Trucklite LED marker lamps (front)	
Electric horn (dual)	

CHASSIS EQUIPMENT

Radiator grille	Chrome
Fuel tank	Aluminum
Fuel pre-filter	Pre-filter (dust) and sediment (water)
Reflectors	Two rear, two front side
Tow hook	One at front
Air dryer	NABCO, heated
Air tank	4.9L

Extended cab	30" cab extension, available with full-width bench seat or 26" day bunk
--------------	---

OPTIONAL EQUIPMENT

Alternator - 12 V, 105 A, brushless Denso
Battery - Three parallel connection each 12 V (GR27 x 3)
Bumper, front - Black and 4 inch extension
Bumper, front - White and 4 inch extension
Bumper, front - Chrome and 4 inch extension
Bumper, front - Chrome (available with one or two tow hooks)
Cold weather package - Heated mirrors (available in chrome) - Engine block heater
Engine block heater
Engine idle throttle knob - Removed
Exhaust brake - Disengage
Mirrors, outside rearview - Heated with marker light
Mirrors, outside rearview - Chrome
Mirrors, outside rearview - Chrome, heated with marker light
Power windows and power door locks
Seat - Driver's seat with air suspension
Seating capacity - Two person
Seats - Vinyl with reclining single person passenger seat
Seats - Fabric with reclining single person passenger seat
Seats - Fabric with two person bench seat
Shock absorbers, rear
Stabilizer, front - With shock absorber
Tire pattern - Rib on rear
Tow Hooks - Two at front

NOTE:

All specifications of the products are with normal manufacturing allowances and tolerances. HINO MOTORS SALES U.S.A., INC. reserves the right to alter specifications at any time without previous notice. Some optional items of equipment may require extra time due to the need for their adaptation on the product line.

FORM NO. HSS 145 0309