

2010

SPECIFICATIONS

HINO 165

4 x 2 Conventional GVW: 16,000 lbs. BBC: 98" Engine Model: J05D-TF (Turbo Intercooled)

DIMENSIONS (On standard specification)

Wheelbase/Code	A in.	147.0/F	169.0/J	183.0/K	201.0/M
Overall length	B in.	244.6	266.6	292.6	310.6
Overall width	C in.	90.4	90.4	90.4	90.4
Overall height	D in.	101.4	101.4	101.4	101.4
Cab to axle	E in.	83.6	105.6	119.6	137.6
Rear overhang	F in.	63.0	63.0	75.0	75.0
Frame height at:	G in.	30.1	30.1	30.1	30.1
	H in.	34.1	34.1	34.1	34.1
Road clearance (at front axle)	J in.	7.1	7.1	7.1	7.1
Tread:	K in.	72.8	72.8	72.8	72.8
	L in.	71.1	71.1	71.1	71.1
Turning radius:	ft.	40.6	46.0	49.4	53.8
	ft.	43.4	48.8	52.2	56.6

CHASSIS WEIGHTS (On standard specification, without spare tire & standard tool set)

MT	Total weight	lb.	7,040	7,130	7,190	7,230
	Front axle	lb.	4,625	4,740	4,785	4,850
	Rear axle	lb.	2,415	2,390	2,405	2,380
AT	Total weight	lb.	7,120	7,220	7,280	7,310
	Front axle	lb.	4,695	4,815	4,875	4,920
	Rear axle	lb.	2,425	2,405	2,405	2,390

ENGINE

Model	HINO J05D-TF
Type	Diesel 4-cycle, 4-cylinder in-line water-cooled, dry cylinder line
Combustion system	Direct injection type
Max. output (SAE Gross)	175HP at 2,500 rpm
Max. torque (SAE Gross)	376 lb.-ft. at 1,600 rpm
Bore and stroke	4.41 x 4.72 in.
Piston displacement	4.730L
Fuel injection pump	Radial plunger pump (HP-3)
Governor	Electronically controlled
Intake system	Turbocharged and intercooled
Air cleaner	Paper filter type (Donaldson)
Fan clutch	Bimetal thermostat sensor regulates fan speed
Glow plugs	Standard
Air compressor	Single cylinder, 6.8 cfm @ 1,250 rpm

POWERTRAIN AND PERFORMANCE

16,000 lbs. GVW and 225-70R19.5 tires			
Powertrain	<input type="checkbox"/> STD.	<input type="checkbox"/> OPT.	<input type="checkbox"/> OPT.
Max. speed mph	78	75*	71*
Startability (tan.θ) %	54.2	56.3	60.0
Transmission Model	Eaton FS4205A	Allison 1000HS/RDS	
	Type	Five-speed direct drive synchromesh 2nd-5th	Six-speed automatic
Ratios	1st.	8.052	3.102
	2nd.	4.352	1.811
	3rd.	2.448	1.406
	4th.	1.476	1.000
	5th.	1.000	0.712
	6th.	—	0.610
	Rev.	8.052	4.492
Rear axle gear ratios	3.580	4.780	5.130

(*) Maximum speed is limited with speed limiter

ROADSIDE ASSISTANCE

HinoWatch (service free of charge)	3-year unlimited roadside assistance
	<ul style="list-style-type: none"> • Lockout • Out of Fuel • Battery Jumpstart • Information • Warranty Towing (2 year coverage)

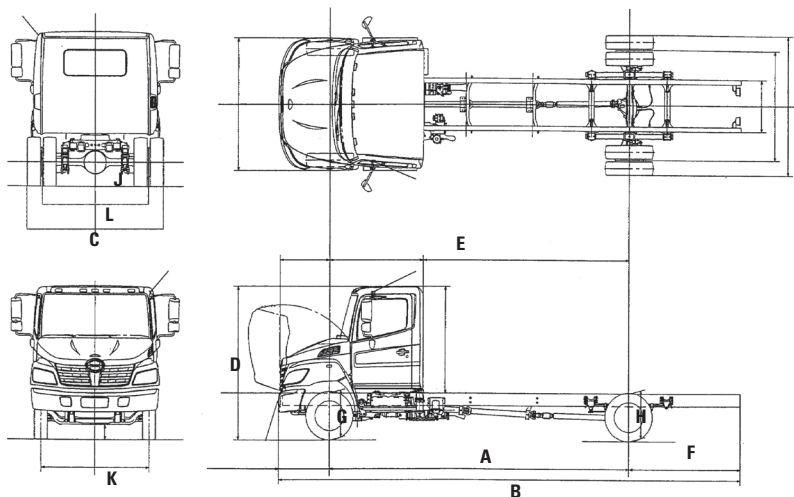

WEIGHT CAPACITIES

Front axle	lbs.	6,250
Rear axle	lbs.	11,000
Front spring	lbs.	6,000
Rear spring	lbs.	12,000

LIQUID CAPACITIES

Fuel tank	gal.	35
Cooling system	gal.	5.29 : Eaton FS4205A 5.16 : Allison 1000HS
Engine oil	qt.	10.73

AXLE/SUSPENSION

Front axle	MFS6 series reversed Elliot, "I" beam (oil lubricated type)
Front spring	Taper-leaf springs shock absorbers
Rear axle	MS113 series Full-floating, single reduction Single-speed by hypoid gearings
Rear spring	Semi-elliptic main and auxiliary helper-leaf spring

FRAME

Ladder type		Straight C Channel
Width	in.	34
Yield strength	PSI	80,000
Resisting bending moment (one side)	in.-lbs.	655,100 no reinforcement

STEERING

Steering column	Tilt and telescopic with lock adjustability
Steering system	TRW recirculating ball, with hydraulic booster, integral type

CLUTCH

Type	Dry single plate with damper springs Eaton-Spicer AR350 series
Facing material	Cerametalllic
Facing outside (in.)	13.8
Control	Hydraulic

WHEELS/TIRES

6 Wheels	19.5 x 6.00RW 8-stud disc.
Wheel style	Steel, powder coated
6 Tires	225/70R19.5(F)
Tire brand and pattern	Bridgestone Fr-rib Rr-lug type

BRAKES

Service brake	Hydraulic system with disc brake for front and rear wheels, with automatic adjustment
Disc diameter x pad area x thickness (in.)	Front; 12.756 x 17.05 x 0.61 Rear; 12.756 x 17.05 x 0.61
Control	Hydraulic dual circuit with Antilock Brake System(ABS)
Parking brake	Mechanical, internal expanding acting on transmission output shaft
Parking brake drum diameter (in.)	10 : Meritor (Auto) 9 : Bosch (Manual)
Exhaust brake	Electric-pneumatic with valve in exhaust pipe

CAB EQUIPMENT

Air conditioning	Standard
Cab construction	All steel welded
Cigarette lighter	Equipped
Coat hook	One (rear panel)
Cruise control	Standard
Cup holders	Two at center cluster (Single)-for MT, (Dual)-for AT
Door pockets	Two
Driver's seat	Adjustable reclining, covered with vinyl with coil suspension
Heater/Defroster	18,357 BTU/h
Mirrors, outside rearview	Four, 1-flat and 1-convex at each side
Over-head consoles	Two
Passenger's seat	Bench type, covered with vinyl
Seat belts	3-point type (driver and passenger), one 2-point type (center)
Seating capacity	Three
Speakers	Two for front
Sun visors	Two
Ventilator	Electric forced air
Windshield	Laminated
Windshield wipers	Dual electric, 2-speed and intermittent

DASH INSTRUMENTATION

Meters and gauges ft. lb. system	
Speedometer-mph (km/h)	
Odometer (mile)	
Fuel gauge	
Coolant temperature gauge	
Engine tachometer	
Warning and pilot lamps and buzzers	
Oil pressure warning lamp and buzzer	
Brake pressure warning lamp and buzzer	
Coolant level warning lamp and buzzer	
Battery charging warning lamp	
High beam indicator lamp	
Turn signal pilot lamp	
Parking brake warning lamp	
Engine control system warning lamp	
ABS warning lamp	
Driver Information Display	
Instant and trip fuel consumption	
DPR monitor	
Maintenance	
Engine/vehicle diagnostics	

ELECTRICAL EQUIPMENT

Batteries	Two, parallel connection, each 12V
Capacity	1200 CCA
Alternator	12 V, 100 A, brush Delco
Starter	12 V, 2.5 kW Denso
Car audio	AM/FM radio with CD
Headlamps	Daytime running - integrated with turn signal and hazard lamps
Stop/Tail lamps	
Back-up lamps	
Side-flasher lamp	
Front side marker lamps	
Trucklite LED marker lamps (front)	
Electric horn (dual)	

CHASSIS EQUIPMENT

Radiator grille	Chrome
Fuel tank	Aluminum
Fuel pre-filter	Heated pre-filter (dust) and sedimentor (water)
Reflectors	Two rear, two front side
Tow hook	One at front
Air dryer	NABCO, heated
Air tank	4.9L

CAB CONFIGURATION OPTIONS

Extended cab	30" cab extension, available with full-width bench seat or 26" day bunk
--------------	---

OPTIONAL EQUIPMENT

Alternator - 12 V, 105 A, brushless Denso
Battery - Three parallel connection each 12 V (GR27-3)
Bumper, front - Black and 4 inch extension
Bumper, front - White and 4 inch extension
Bumper, front - Chrome and 4 inch extension
Bumper, front - Chrome (available with one or two tow hooks)
Engine block heater
Cold weather package - Heated mirrors (available in chrome) - Engine block heater
Engine idle throttle knob - Removed
Exhaust brake - Disengage
Mirrors, outside rearview - Chrome
Mirrors, outside rearview - Chrome, heated with marker light
Mirrors, outside rearview - Heated with marker light
Power windows and power door locks
Seat - Driver's seat with air suspension
Seats - Fabric with reclining single person passenger seat
Seats - Fabric with two person bench seat
Seats - Vinyl with reclining single person passenger seat
Seating capacity - Two person
Shock absorbers, rear
Stabilizer, front - With shock absorber
Synthetic fluids - Auto/manual transmission and rear differential
Tire pattern - Rib on rear
Tow hooks - Two at front
Transmission, automatic - Allison 1000 RDS with PTO drive gear (rear axle ratio 5.13)
Transmission, automatic - Allison 1000 HS (rear axle ratio 4.78)
Wheels - Alcoa polished aluminum

NOTE:

All specifications of the products are with normal manufacturing allowances and tolerances. HINO MOTORS SALES U.S.A., INC. reserves the right to alter specifications at any time without previous notice. Some optional items of equipment may require extra time due to the need for their adaptation on the product line.

FORM NO. HSS 165 0309