

# 2010

# HINO 238

## SPECIFICATIONS

4 x 2 Conventional GVW: 23,000 lbs. BBC: 108" Engine Model: J08E-TV (Turbo Intercooled)

### DIMENSIONS (On standard specification)

Wheelbase/Code	A in.	175.0/J	187.0/L	205.0/M	217.0/P	235.0/R	253.0/T
Overall length	B in.	278.6	302.6	320.6	354.6	372.6	390.6
Overall width	C in.	95.7	95.7	95.7	95.7	95.7	95.7
Overall height	D in.	106.1	106.1	106.1	106.1	106.1	106.1
Cab to axle	E in.	107.6	119.6	137.6	149.6	167.6	185.6
Rear overhang	F in.	63.0	75.0	75.0	97.0	97.0	97.0
Frame height at:	Front axle	G in.	36.2	36.2	36.2	36.2	36.2
	Rear axle	H in.	39.0	39.0	39.0	39.0	39.0
Road clearance (at diff. axle)	J in.	10.6	10.6	10.6	10.6	10.6	10.6
Tread:	Front	K in.	78.0	78.0	78.0	78.0	78.0
	Rear	L in.	72.0	72.0	72.0	72.0	72.0
Turning radius:	Curb to Curb	ft.	47.8	50.8	55.2	58.1	62.5
	Wall to wall	ft.	51.3	54.3	58.6	61.6	66.0

### CHASSIS WEIGHTS (On standard specification, without spare tire & standard tool set)

AT	Total weight	lb.	9,260	9,330	9,440	9,550	9,620	9,660
	Front axle	lb.	5,845	5,900	6,000	6,025	6,095	6,145
	Rear axle	lb.	3,415	3,430	3,440	3,525	3,525	3,515

### ENGINE

Model	HINO J08E-TV
Type	Diesel 4-cycle, 6-cylinder in-line water-cooled, dry cylinder line
Combustion system	Direct injection type
Max. output (SAE Gross)	220HP at 2,500 rpm
Max. torque (SAE Gross)	520 lb.-ft. at 1,500 rpm
Bore and stroke	4.41 x 5.12 in.
Piston displacement	7.680L
Fuel injection pump	Radial plunger pump (HP-4)
Governor	Electronically controlled
Intake system	Turbocharged and intercooled
Air cleaner	Paper filter type (Donaldson)
Fan clutch	Bimetal thermostat sensor regulates fan speed
Glow plugs	Standard
Air compressor	Single cylinder, 6.8 cfm @ 1,250 rpm

### POWERTRAIN AND PERFORMANCE

23,000 lbs. GVW		
Powertrain	<input type="checkbox"/> STD.	<input type="checkbox"/> OPT.
Max. speed mph	79*	78*
Startability (tan.θ) %	38.6	38.8
Transmission Model	Allison 2200HS/RDS	
Type	Six-speed automatic	
Ratios	1st.	3.102
	2nd.	1.811
	3rd.	1.406
	4th.	1.000
	5th.	0.712
	6th.	0.610
Rev.	4.492	
Rear axle gear ratios	5.290	5.130
Tires (standard ratio)	10R22.5-14	255/80R22.5

(\*) Maximum speed is limited with speed limiter

### ROADSIDE ASSISTANCE

HinoWatch (service free of charge)	3-year unlimited roadside assistance
	<ul style="list-style-type: none"> <li>• Lockout</li> <li>• Out of Fuel</li> <li>• Battery Jumpstart</li> <li>• Information</li> <li>• Warranty Towing (2 year coverage)</li> </ul>

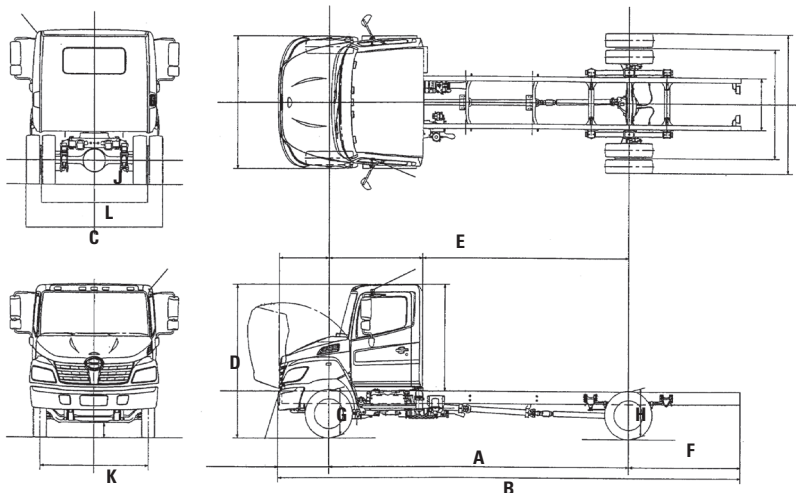

## WEIGHT CAPACITIES

Front axle	lbs.	8,000
Rear axle	lbs.	17,500
Front spring	lbs.	8,000
Rear spring	lbs.	19,000

## LIQUID CAPACITIES

Fuel tank	gal.	52
Cooling system	gal.	6.08
Engine oil	qt.	16.15

## AXLE/SUSPENSION

Front axle	MFS-8 series reversed Elliot, "I" beam (oil lubricated type)
Front spring	Taper-leaf springs shock absorbers
Rear axle	RS17-145 series Full-floating, single reduction Single-speed by hypoid gearings
Rear spring	Semi-elliptic main and auxiliary helper-leaf spring

## FRAME

Ladder type		Straight C Channel
Width	in.	34
Yield strength	PSI	80,000
Resisting bending moment (one side)	in-lbs.	1,031,900 no reinforcement

## STEERING

Steering column adjustability	Tilt and telescopic with lock adjustability
Steering system	TRW recirculating ball, with hydraulic booster, integral type

## WHEELS/TIRES

6 Wheels	22.2 x 8.25 10-stud disc.
Wheel style	Steel, powder coated
6 Tires	10R22.5(G)
Tire brand and pattern	Bridgestone Fr-rib/Rr-lug type

## BRAKES

Service brake	Hydraulic system with disc brake for front and rear wheels, with automatic adjustment
Disc diameter) x pad area (in <sup>2</sup> x thickness (in.))	Front: 15.375 x 18.96 x 0.74 Rear: 15.375 x 18.96 x 0.74
Control	Hydraulic dual circuit with Antilock Brake System(ABS)
Parking brake	Mechanical, internal expanding acting on transmission output shaft
Parking brake drum diameter (in.)	9 : Bosch
Exhaust brake	Electric pneumatic with valve in exhaust pipe

## CHASSIS EQUIPMENT

Radiator grille	Chrome
Fuel tank	Aluminum
Fuel pre-filter	Heated pre-filter (dust) and sedimentor (water)
Reflectors	Two rear, two front side
Tow hook	One at front
Air dryer	NABCO, heated
Air tank	4.9L

## CAB EQUIPMENT

Air conditioning	Standard
Cab construction	All steel welded
Cigarette lighter	Equipped
Coat hook	One (rear panel)
Cruise control	Standard
Cup holders	Two at center cluster
Door pockets	Two
Driver's seat	Adjustable reclining, covered with vinyl with coil suspension
Heater/Defroster	18,357 BTU/h
Mirrors, outside rearview	Four, 1-flat and 1-convex at each side
Over-head consoles	Two
Passenger's seat	Bench type, covered with vinyl
Seat belts	3-point type (driver and passenger), one 2-point type (center)
Seating	Three
Speakers	Two for front
Sun visors	Two
Ventilator	Electric forced air
Windshield	Laminated
Windshield wipers	Dual electric, 2-speed and intermittent

## DASH INSTRUMENTATION

Meters and gauges ft. lb. system	
Speedometer-mph (km/h)	
Odometer (mile)	
Fuel gauge	
Coolant temperature gauge	
Engine tachometer	
Warning and pilot lamps and buzzers	
Oil pressure warning lamp and buzzer	
Brake pressure warning lamp and buzzer	
Coolant level warning lamp and buzzer	
Battery charging warning lamp	
High beam indicator lamp	
Turn signal pilot lamp	
Parking brake warning lamp	
Engine control system warning lamp	
ABS warning lamp	
Driver Information Display	
Instant and trip fuel consumption	
DPR monitor	
Maintenance schedule	
Engine/vehicle diagnostics	

## ELECTRICAL EQUIPMENT

Batteries	Two, parallel connection, each 12V
Capacity	1200 CCA
Alternator	12 V, 100 A, brush Delco
Starter	12 V, 4.8 kW Denso
Car audio	AM/FM radio with CD
Headlamps	Daytime running - integrated with turn signal and hazard lamps
Stop/Tail lamps	
Back-up lamps	
Side-flasher lamp	
Dome lamp	
Front side marker lamps	
Trucklite LED cab marker lamps (front)	
Electric horn (dual)	

## CAB CONFIGURATION OPTIONS

Extended cab	30" cab extension, available with full-width bench seat or 26" day bunk
--------------	---

## OPTIONAL EQUIPMENT

Air horn	
Air ride suspension dump valve - Electric	
Air ride suspension - Hendrickson (N/A on G, J wheelbases)	
Alternator - 12 V, 105 A, brushless Denso	
Battery - Absorbed glass mat (AGM) 31 Configuration, 1600 CCA	
Battery - Three parallel connection each 12 V (GR27x3)	
Battery - Two or three parallel connection each 12 V (GR31 type)	
Bumper, front - Black and 4 inch extension (available 3 piece)	
Bumper, front - White and 4 inch extension (available 3 piece)	
Bumper, front - White 3 piece (available with one or two tow hooks)	
Bumper, front - Chrome and 4 inch extension	
Bumper, front - Chrome (available with one or two tow hooks)	
Cab paint, exterior - Black or Red	
Cold weather package	
- Heated mirrors (available in chrome)	
- Engine block heater	
Engine block heater	
Engine idle throttle knob - Removed	
Exhaust brake - Disengage	
Exhaust system - Vertical stack type (N/A with 95 gal. fuel tank)	
Fuel tank - Dual 52 gal. (N/A on G wheelbase)	
Fuel tank - Single 95 gal.	
Mirrors, outside rearview - Chrome, heated with marker light	
Mirrors, outside rearview - Chrome	
Mirrors, outside rearview - Heated with marker light	
Power windows and power door locks	
Seat - Driver's seat with air suspension	
Seats - Vinyl with reclining single person passenger seat	
Seats - Fabric with reclining single person passenger seat	
Seats - Fabric with two person bench seat	
Seating capacity - Two person	
Shock absorbers, rear	
Stabilizer, rear	
Stabilizer, rear - With shock absorbers	
Synthetic fluids - Auto transmission and rear differential	
Tire pattern - Rib on rear	
Tire size - 255/80R22.5-14(G) Michelin	
Tow hooks - Two at front	
Transmission, automatic - Allison 2200 RDS with PTO drive gear (rear axle ratio 5.13)	
Wheels - Alcoa polished aluminum	

## NOTE:

All specifications of the products are with normal manufacturing allowances and tolerances. HINO MOTORS SALES U.S.A., INC. reserves the right to alter specifications at any time without previous notice. Some optional items of equipment may require extra time due to the need for their adaptation on the product line.

FORM NO. HSS 238 0309