

# 2010

# HINO 258ALP

## SPECIFICATIONS

4 x 2 Conventional

GVW: 25,550 lbs.

BBC: 108"

Engine Model: J08E-TV (Turbo Intercooled)

### DIMENSIONS (On standard specification)

Wheelbase/Code	A in.	152.0/G	175.0/J	187.0/L	205.0/M	212.0/N	217.0/P	235.0/R	253.0/T	271.0/V
Overall length	B in.	242.6	278.6	302.6	320.6	354.6	354.6	372.6	390.6	390.6
Overall width	C in.	95.7	95.7	95.7	95.7	95.7	95.7	95.7	95.7	95.7
Overall height	D in.	102.4	102.4	102.4	102.4	102.4	102.4	102.4	102.4	102.4
Cab to axle	E in.	84.6	107.6	119.6	137.6	144.6	149.6	167.6	185.6	203.6
Rear overhang	F in.	50.0	63.0	75.0	75.0	102.0	97.0	97.0	97.0	79.0
Frame height at:	G in.	32.5	32.5	32.5	32.5	32.5	32.5	32.5	32.5	32.5
	H in.	35.4	35.4	35.4	35.4	35.4	35.4	35.4	35.4	35.4
Road clearance (at diff. axle)	J in.	7.1	7.1	7.1	7.1	7.1	7.1	7.1	7.1	7.1
Tread:	K in.	78.3	78.3	78.3	78.3	78.3	78.3	78.3	78.3	78.3
	L in.	72.4	72.4	72.4	72.4	72.4	72.4	72.4	72.4	72.4
Turning radius:	ft.	42.3	47.9	50.9	55.3	57.0	58.2	62.6	67.0	71.4
	ft.	45.7	51.3	54.2	58.7	60.3	61.6	66.0	70.4	74.8

### CHASSIS WEIGHTS (On standard specification, without spare tire & standard tool set)

	Total weight	lb.	9,390	9,350	9,410	9,520	9,630	9,630	9,710	9,740	9,790
AT	Front axle	lb.	5,850	5,865	5,915	6,015	6,025	6,025	6,115	6,160	6,250
	Rear axle	lb.	3,540	3,485	3,495	3,505	3,605	3,605	3,595	3,580	3,540
	Total weight	lb.	9,510	9,470	9,530	9,650	9,760	9,760	9,830	9,870	9,910
AMT	Front axle	lb.	5,970	5,985	6,035	6,145	6,155	6,155	6,235	6,290	6,370
	Rear axle	lb.	3,540	3,485	3,495	3,505	3,605	3,605	3,595	3,580	3,540

### ENGINE

Model	HINO J08E-TV
Type	Diesel 4-cycle, 6-cylinder in-line water-cooled, dry cylinder line
Combustion system	Direct injection type
Max. output (SAE Gross)	220HP at 2,500 rpm
Max. torque (SAE Gross)	520 lb.-ft. at 1,500 rpm
Bore and stroke	4.41 x 5.12 in.
Piston displacement	7.680L
Fuel injection pump	Radial plunger pump (HP-4)
Governor	Electronically controlled
Intake system	Turbocharged and intercooled
Air cleaner	Paper filter type (Donaldson)
Fan clutch	Bimetal thermostat sensor regulates fan speed
Glow plugs	Standard
Air compressor	Single cylinder, 10.0 cfm @ 1,250 rpm

### POWERTRAIN AND PERFORMANCE

25,550 lbs. GVW and 11R22.5 tires			
Powertrain	<input type="checkbox"/> STD.	<input type="checkbox"/> OPT.	
Max. speed mph	84*	81*	
Startability (tan.θ) %	31.8	37.7	
Transmission Model	Allison 2200 RDS	Eaton F05406B	
Type	Six-speed automatic	Six-speed Direct drive synchromesh 1st - 6th	
Ratios	1st.	3.102	6.545
	2nd.	1.811	4.125
	3rd.	1.406	2.518
	4th.	1.000	1.591
	5th.	0.712	1.000
	6th.	0.610	0.781
	Rev.	4.492	6.273
Rear axle gear ratios	4.110	3.900	

(\* Maximum speed is limited with speed limiter)

### ROADSIDE ASSISTANCE

HinoWatch (service free of charge)	3-year unlimited roadside assistance <ul style="list-style-type: none"> <li>• Lockout</li> <li>• Out of Fuel</li> <li>• Battery Jumpstart</li> <li>• Information</li> <li>• Warranty Towing (2 year coverage)</li> </ul>
------------------------------------	--

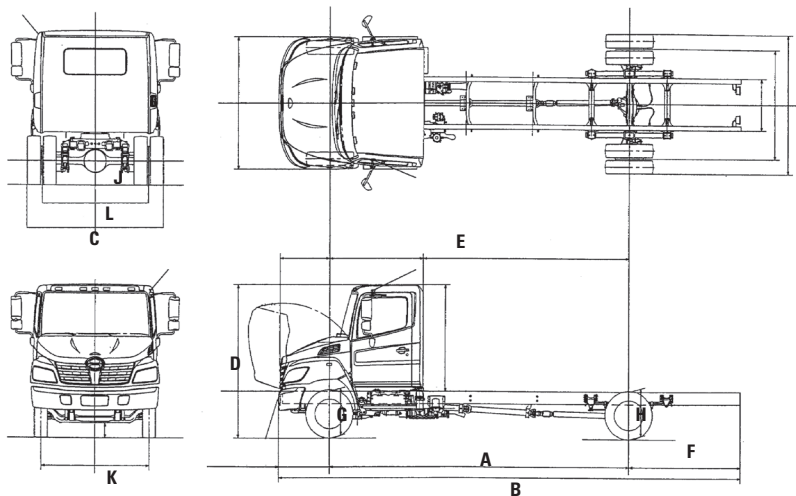

## WEIGHT CAPACITIES

Front axle	lbs.	8,000
Rear axle	lbs.	17,500
Front spring	lbs.	8,000
Rear spring	lbs.	19,000

## LIQUID CAPACITIES

Fuel tank	gal.	52
Cooling system	gal.	6.08: Allison 2200 RDS 6.21: Eaton FO5406B
Engine oil	qt.	16.15

## AXLE/SUSPENSION

Front axle	MFS-8 series reversed Elliot, "I" beam (oil lubricated type)
Front spring	Taper-leaf springs shock absorbers
Rear axle	RS17-145 series Full-floating, single reduction Single-speed by hypoid gearings with oil lubricated type
Rear spring	Semi-elliptic main and auxiliary helper-leaf spring

## FRAME

Ladder type		Straight C Channel
Width	in.	34
Yield strength	PSI	80,000
Resisting bending moment (one side)	in.-lbs.	1,031,900 no reinforcement

## STEERING

Steering column	Tilt and telescopic with lock adjustability
Steering system	TRW recirculating ball, with hydraulic booster, integral type

## WHEELS/TIRES

6 Wheels	19.5 x 6.75 10-stud disc.
Wheel style	Steel, powder coated
6 Tires	245/70R19.5(G)
Tire brand and pattern	Bridgestone Fr-rib/Rr-lug type

## BRAKES

Service brake	Full air, dual circuit, "S" cam type, leading and trailing shoes, with automatic adjustment
Drum diameter x lining width x thickness (in.)	Front: 15 x 4 x 0.73 Rear: 16.5 x 7 x 0.83
Control	Full air dual circuit with Antilock Brake System (ABS)
Parking brake type	Spring brake acting on rear wheels
Air dryer for air tank	Equipped
Exhaust brake	Electric-pneumatic with valve in exhaust pipe

## CHASSIS EQUIPMENT

Radiator grille	Chrome
Fuel tank	Aluminum
Fuel pre-filter	Heated pre-filter (dust) and sedimentor (water)
Reflectors	Two rear, two front side
Tow hook	One at front
Air dryer	NABCO, heated
Air tank	68L

## CAB EQUIPMENT

Air conditioning	Standard
Cab construction	All steel welded
Cigarette lighter	Equipped
Coat hook	One (rear panel)
Cruise control	Standard
Cup holders	Two at center cluster
Door pockets	Two
Driver's seat	Adjustable reclining, covered with vinyl with air suspension
Heater/Defroster	18,357 BTU/h
Mirrors, outside rearview	Four, 1-flat and 1-convex at each side
Over-head consoles	Two
Passenger's seat	Bench type, covered with vinyl
Seat belts	3-point type (driver and passenger), one 2-point type (center)
Seating	Three
Speakers	Two for front
Sun visors	Two
Ventilator	Electric forced air
Windshield	Laminated
Windshield wipers	Dual electric, 2-speed and intermittent

## DASH INSTRUMENTATION

Meters and gauges ft. lb. system	
Speedometer-mph (km/h)	
Odometer (mile)	
Fuel gauge	
Coolant temperature gauge	
Engine tachometer	
Air Pressure gauge	
Warning and pilot lamps and buzzers	
Oil pressure warning lamp and buzzer	
Air pressure level warning lamp and buzzer	
Coolant level warning lamp and buzzer	
Battery charging warning lamp	
High beam indicator lamp	
Turn signal pilot lamp	
Parking brake warning lamp	
Engine control system warning lamp	
ABS warning lamp	
Driver Information Display	
Instant and trip fuel consumption	
DPR monitor	
Maintenance schedule	
Engine/vehicle diagnostics	

## ELECTRICAL EQUIPMENT

Batteries	Two, parallel connection, each 12V
Capacity	1200 CCA
Alternator	12 V, 100 A, brush Delco
Starter	12 V, 4.0 kW Denso
Car audio	AM/FM radio with CD
Headlamps	Daytime running - integrated with turn signal and hazard lamps
Stop/Tail lamps	
Back-up lamps	
Front side marker lamps	
Trucklite LED cab marker lamps (front)	
Electrical horn (dual)	

## CAB CONFIGURATION OPTIONS

Extended cab	30" cab extension, available with full-width bench seat or 26" day bunk
Right hand drive, dual-steer, sit down	Driver controls mounted on both sides of cab
Right hand drive, dual-steer, stand-up	Driver controls mounted on both sides of cab, right hand side of cab designed for operation while standing with easy entry / exit

## OPTIONAL EQUIPMENT

Air horn	
Air ride suspension dump valve - Electric	
Air ride suspension - Hendrickson (N/A on G, J wheelbases)	
Alternator - 12 V, 105 A, brushless Denso	
Battery - Absorbed glass mat (AGM) 31 Configuration, 1600 CCA	
Battery - Three parallel connection each 12 V (GR27x3)	
Battery - Two or three parallel connection each 12 V (GR31 type)	
Bumper, front - Black and 4 inch extension (available 3 piece)	
Bumper, front - White and 4 inch extension (available 3 piece)	
Bumper, front - White 3 piece (available with one or two tow hooks)	
Bumper, front - Chrome and 4 inch extension	
Bumper, front - Chrome (available with one or two tow hooks)	
Cab paint, exterior - Black or Red	
Cold weather package	- Heated mirrors - (available in chrome) - Engine block heater - Bendix heated air dryer
Differential lock with controls	
Engine block heater	
Engine idle throttle knob - Removed	
Exhaust brake - Disengage	
Exhaust system - Vertical stack type (N/A with 95 gal. fuel tank)	
Fuel tank - Dual 52 gal. (N/A on G wheelbase)	
Fuel tank - Single 95 gal.	
Mirrors, outside rearview - Chrome	
Mirrors, outside rearview - Chrome, heated with marker light	
Mirrors, outside rearview - Heated with marker light	
Power windows and power door locks	
Seating capacity - Two person	
Seats - Fabric with reclining single person passenger seat	
Seats - Fabric with two person bench seat	
Seats - Vinyl with reclining single person passenger seat	
Shock absorbers, rear	
Stabilizer, rear	
Stabilizer, rear - With shock absorbers	
Synthetic fluids - Auto transmission and rear differential	
Tire pattern - Rib on rear	
Tow hooks - Two at front	
Transmission, automatic - Eaton Ultrashift Highway Value	
Wheels - Alcoa polished aluminum	

## NOTE:

All specifications of the products are with normal manufacturing allowances and tolerances. HINO MOTORS SALES U.S.A., INC. reserves the right to alter specifications at any time without previous notice. Some optional items of equipment may require extra time due to the need for their adaptation on the product line.

FORM NO. HSS 258ALP 0309