

# 2010

## SPECIFICATIONS

# HINO 268A

4 x 2 Conventional

GVW: 25,950 lbs.

BBC: 108"

Engine Model: J08E-TV (Turbo Intercooled)

### DIMENSIONS (On standard specification)

Wheelbase/Code	A in.	152.0/G	175.0/J	187.0/L	205.0/M	217.0/P	235.0/R	253.0/T	271.0/V
Overall length	B in.	242.6	278.6	302.6	320.6	354.6	372.6	390.6	390.6
Overall width	C in.	96.5	96.5	96.5	96.5	96.5	96.5	96.5	96.5
Overall height	D in.	106.9	106.9	106.9	106.9	106.9	106.9	106.9	106.9
Cab to axle	E in.	84.6	107.6	119.6	137.6	149.6	167.6	185.6	203.6
Rear overhang	F in.	50.0	63.0	75.0	75.0	97.0	97.0	97.0	79.0
Frame height at:									
Front axle	G in.	37.0	37.0	37.0	37.0	37.0	37.0	37.0	37.0
Rear axle	H in.	39.8	39.8	39.8	39.8	39.8	39.8	39.8	39.8
Road clearance (at diff. axle)	J in.	11.2	11.2	11.2	11.2	11.2	11.2	11.2	11.2
Tread:									
Front	K in.	79.3	79.3	79.3	79.3	79.3	79.3	79.3	79.3
Rear	L in.	72.2	72.2	72.2	72.2	72.2	72.2	72.2	72.2
Turning radius:									
Curb to Curb	ft.	42.0	47.5	50.4	54.8	57.7	62.0	66.4	70.8
Wall to wall	ft.	45.4	50.9	53.9	58.2	61.1	65.4	69.8	74.2

### CHASSIS WEIGHTS (On standard specification, without spare tire & standard tool set)

	Total weight	lb.	9,930	9,900	9,960	10,070	10,190	10,250	10,300	10,340
MT	Front axle	lb.	6,115	6,140	6,190	6,290	6,310	6,380	6,440	6,525
	Rear axle	lb.	3,815	3,760	3,770	3,780	3,880	3,870	3,860	3,815
	Total weight	lb.	9,890	9,840	9,910	10,020	10,130	10,210	10,240	10,280
AT	Front axle	lb.	6,075	6,080	6,140	6,240	6,250	6,340	6,380	6,465
	Rear axle	lb.	3,815	3,760	3,770	3,780	3,880	3,870	3,860	3,815
	Total weight	lb.	10,000	9,960	10,030	10,130	10,250	10,320	10,360	10,410
AMT	Front axle	lb.	6,185	6,200	6,260	6,350	6,370	6,450	6,500	6,595
	Rear axle	lb.	3,815	3,760	3,770	3,780	3,880	3,870	3,860	3,815

### ENGINE

Model	HINO J08E-TV
Type	Diesel 4-cycle, 6-cylinder in-line water-cooled, dry cylinder line
Combustion system	Direct injection type
Max. output (SAE Gross)	220HP at 2,500 rpm
Max. torque (SAE Gross)	520 lb.-ft. at 1,500 rpm
Bore and stroke	4.41 x 5.12 in.
Piston displacement	7.680L
Fuel injection pump	Radial plunger pump (HP-4)
Governor	Electronically controlled
Intake system	Turbocharged and intercooled
Air cleaner	Paper filter type (Donaldson)
Fan clutch	Bimetal thermostat sensor regulates fan speed
Glow plugs	Standard
Air compressor	Single cylinder, 10.0 cfm @ 1,250 rpm

### POWERTRAIN AND PERFORMANCE

25,950 lbs. GVW							
Powertrain	<input type="checkbox"/> STD.	<input type="checkbox"/> OPT.	<input type="checkbox"/> OPT.	<input type="checkbox"/> OPT.	<input type="checkbox"/> OPT.	<input type="checkbox"/> OPT.	<input type="checkbox"/> OPT.
Max. speed mph	75*	77*	77*	78*	77*	75*	76*
Startability (tan.θ)%	44.2	42.6	34.3	33.7	39.8	40.7	40.0
Transmission	Model	Eaton FS5406A	Allison 2200HS/RDS	Allison 2500RDS	Eaton F05406B AMT		
	Type	Six-speed Direct drive synchromesh 1st-6th	Six-speed automatic		Six-speed Direct drive synchromesh 1st-6th		
Ratios	1st.	9.008	3.102	3.512	6.545		
	2nd.	5.270	1.811	1.896	4.125		
	3rd.	3.220	1.406	1.439	2.518		
	4th.	2.040	1.000	1.000	1.591		
	5th.	1.361	0.712	0.737	1.000		
	6th.	1.000	0.610	0.640	0.781		
	Rev.	8.625	4.492	5.086	6.273		
Rear axle gear ratios	4.110	3.730	5.570	5.130	5.570	5.290	4.880
Tires (standard ratio)	11R22.5-14	255/80R22.5	11R22.5-14	255/80R22.5	11R22.5-14	11R22.5-14	255/80R22.5

(\*) Maximum speed is limited with speed limiter

### ROADSIDE ASSISTANCE

HinoWatch, service free of charge. 3-year unlimited roadside assistance includes: lockout, out of fuel, battery jumpstart, information and warranty towing (2 year coverage).

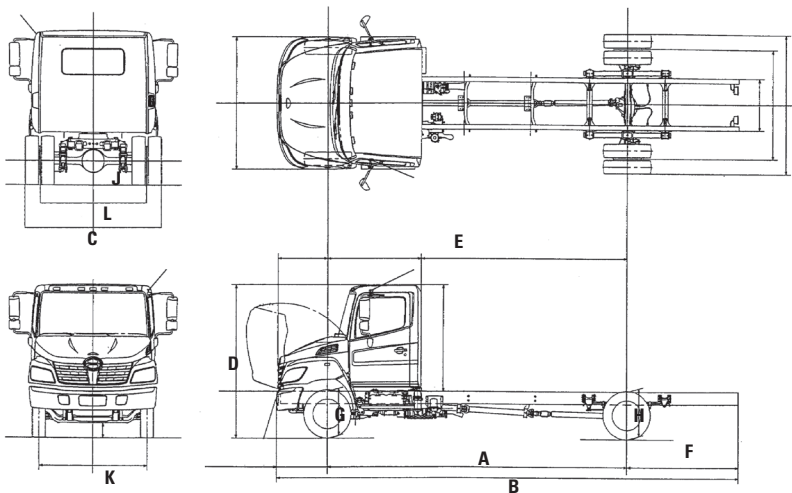

## WEIGHT CAPACITIES

Front axle	lbs.	10,000
Rear axle	lbs.	19,000
Front spring	lbs.	12,000
Front spring (option)	lbs.	8,000
Rear spring	lbs.	21,000

## LIQUID CAPACITIES

Fuel tank	gal.	52
Cooling system	gal.	6.21: Eaton FS5406A/B 6.08: Allison 2200HS
Engine oil	qt.	16.15

## AXLE/SUSPENSION

Front axle	MFS-10 series reversed Elliot, "I" beam (oil lubricated type)
Front spring	Taper-leaf springs shock absorbers
Rear axle	RS19-145 series Full-floating, single reduction Single-speed by hypoid gearings with oil lubricated type
Rear spring	Semi-elliptic main and auxiliary helper-leaf spring

## FRAME

Ladder type		Straight C Channel
Width	in.	34
Yield strength	PSI	80,000
Resisting bending moment (one side)	in.-lbs.	1,031,900 no reinforcement

## STEERING

Steering column	Tilt and telescopic with lock adjustability
Steering system	TRW recirculating ball, with hydraulic booster, integral type

## CLUTCH

Type	Dry single plate with damper springs EATON-SPICER SAS 1401 series
Facing material	Cerametallic
Facing outside (in.)	13.8
Control	Hydraulic

## BRAKES

Service brake	Full air, dual circuit, "S" cam type, leading and trailing shoes, with automatic adjustment
Disc diameter x lining width x thickness (in.)	Front: 15 x 4 x 0.73 Rear: 16.5 x 7 x 0.85
Control	Full air dual circuit with Antilock Brake System (ABS)
Parking brake	Spring brake on rear wheels
Air dryer for air tank	Equipped
Exhaust brake	Electric-pneumatic with valve in exhaust pipe

## CHASSIS EQUIPMENT

Radiator grille	Chrome
Fuel tank	Aluminum
Fuel pre-filter	Heated pre-filter (dust) and sedimenter (water)
Reflectors	Two rear, two front side
Tow hook	One at front
Air dryer	NABCO, heated
Air tank	68L

## CAB EQUIPMENT

Air conditioning	Standard
Cab construction	All steel welded
Cigarette lighter	Equipped
Coat hook	One (rear panel)
Cruise control	Standard
Cup holder	Two at center cluster (Single) - for MT, (Dual) - for AT
Door pockets	Two
Driver's seat	Adjustable reclining, covered with vinyl with air suspension
Heater/Defroster	18,357 BTU/h
Mirrors, outside rearview	Four, 1-flat and 1-convex at each side
Over-head consoles	Two
Passenger's seat	Bench type, covered with vinyl
Seat belts	3-point type (driver and passenger), one 2-point type (center)
Seating	Three
Sun visors	Two
Speakers	Two for front
Ventilator	Electric forced air
Windshield	Laminated
Windshield wipers	Dual electric, 2-speed and intermittent

## DASH INSTRUMENTATION

Meters and gauges	ft. lb. system
Speedometer-mph (km/h)	
Odometer (mile)	
Fuel gauge	
Coolant temperature gauge	
Engine tachometer	
Air pressure gauge	
Warning and pilot lamps and buzzers	
Oil pressure warning lamp and buzzer	
Air pressure warning lamp and buzzer	
Coolant level warning lamp and buzzer	
Battery charging warning lamp	
High beam indicator lamp	
Turn signal pilot lamp	
Parking brake warning lamp	
Engine control system warning lamp	
ABS warning lamp	
Driver Information Display	
Instant and trip fuel consumption	
DPR monitor	
Maintenance schedule	
Engine/vehicle diagnostics	

## ELECTRICAL EQUIPMENT

Batteries	Two, parallel connection, each 12V
Capacity	1200 CCA
Alternator	12 V, 100 A, brush Delco
Starter	12 V, 4.0 kW Denso
Car audio	AM/FM radio with CD
Headlamps	Daytime running - integrated with turn signal and hazard lamps
Stop/Tail lamps	
Back-up lamps	
Side-flasher lamp	
Front side marker lamps	
Trucklite LED cab marker lamps (front)	
Electrical horn (dual)	

## WHEELS/TIRES

6 Wheels	22.5 x 8.25 10-stud disc.
Wheel style	Steel, powder coated
6 Tires	11R22.5(G)
Tire brand and pattern	Bridgestone Fr-rib/Rr-lug type

## CAB CONFIGURATION OPTIONS

Extended cab	30" cab extension, available with full-width bench seat or 26" day bunk
Right hand drive, dual-steer, sit down	Driver controls mounted on both sides of cab
Right hand drive, dual-steer, stand-up	Driver controls mounted on both sides of cab, right hand side of cab designed for operation while standing with easy entry / exit

## OPTIONAL EQUIPMENT

Air horn	
Air ride suspension dump valve - Electric	
Air ride suspension - Hendrickson (N/A on G, J wheelbases)	
Alternator - 12 V, 105 A, brushless Denso	
Battery - Absorbed glass mat (AGM) 31 Configuration	
Battery - Two or three parallel connection each 12 V (GR31 type)	
Battery - Three parallel connection each 12 V (GR27x3)	
Bumper, front - Black and 4 inch extension (available 3 piece)	
Bumper, front - White and 4 inch extension (available 3 piece)	
Bumper, front - White 3 piece (available with one or two tow hooks)	
Bumper, front - Chrome and 4 inch extension	
Bumper, front - Chrome (available with one or two tow hooks)	
Cab paint, exterior - Black or red	
Cold weather package	
- Heated mirrors (available in chrome)	
- Engine block heater	
- Bendix air dryer	
Clutch - Eaton 1401 self-adjusting solo	
Clutch - Eaton 1402 twin plate self-adjusting solo	
Differential lock with controls	
Engine block heater	
Engine idle throttle knob - Removed	
Exhaust brake - Disengage	
Exhaust system - Vertical stack type (N/A with 95 gal. fuel tank)	
Fuel tank - Dual 52 gal. (N/A on G wheelbase)	
Fuel tank - Single 95 gal.	
Mirrors, outside rearview - Chrome	
Mirrors, outside rearview - Chrome, heated with marker light	
Mirrors, outside rearview - Heated with marker light	
Power windows and power door locks	
Seats - Fabric with reclining single person passenger seat	
Seats - Fabric with two person bench seat	
Seats - Vinyl with reclining single person passenger seat	
Shock absorbers, rear	
Stabilizer, rear	
Stabilizer, rear - With shock absorbers	
Synthetic fluids - Auto/manual transmission and rear differential	
Tire pattern - Rib on rear	
Tire size - 255/70R22.5-16(H) Bridgestone	
Tire size - 295/75R22.5-14(G) Bridgestone	
Tire size - 255/80R22.5-14(G) Michelin	
Transmission, automatic - Allison 2200 HS (rear axle ratio 5.57)	
Transmission, automatic - Allison 2200 RDS (rear axle ratio 5.13)	
Transmission, automatic - Allison 2500 RDS (rear axle ratio 5.57)	
Transmission, automatic - Eaton Ultrashift Highway Value	
Wheels - Alcoa polished aluminum	

## NOTE:

All specifications of the products are with normal manufacturing allowances and tolerances. HINO MOTORS SALES U.S.A., INC. reserves the right to alter specifications at any time without previous notice. Some optional items of equipment may require extra time due to the need for their adaptation on the product line.

FORM NO. HSS 268A 0309