

# HINO 185

4 x 2 CONVENTIONAL  
GVW 18,000 lbs. BBC 98"  
ENGINE MODEL J05D-TA (Turbo Intercooled)

## DIMENSIONS (On standard specification)

Production code		NC6JJSA	NC6JKSA	NC6JMSA
Wheelbase code		J	K	M
Wheelbase	A in.	169.0	183.0	201.0
Overall length	B in.	266.6	292.6	310.6
Overall width	C in.	91.1	91.1	91.1
Overall height	D in.	101.0	101.0	101.0
Cab to axle	E in.	105.6	119.6	137.6
Rear overhang	F in.	63.0	75.0	75.0
Frame height at				
Front axle	G in.	30.1	30.1	30.1
Rear axle	H in.	33.7	33.7	33.7
Road clearance				
(at front axle)	J in.	7.1	7.1	7.1
Tread				
Front	K in.	72.8	72.8	72.8
Rear	L in.	71.9	71.9	71.9
Cab height	in.	70.0	70.0	70.0
Turning radius 180°				
Tire	in.	552.0	592.9	645.7
Wall to wall	in.	585.8	626.8	679.5

## CHASSIS WEIGHTS (On std. spec.)

Total weight	MT lb.	7,240	7,275	7,320
Front axle	MT lb.	4,695	4,720	4,785
Rear axle	MT lb.	2,545	2,555	2,535
Total weight	AT lb.	7,155	7,200	7,230
Front axle	AT lb.	4,610	4,650	4,695
Rear axle	AT lb.	2,545	2,550	2,535

## POWER LINE & PERFORMANCE

18,000 lbs. GVW & 225-70R19.5 tires

Power line	Manual	Automatic	
	STD.	OPT.	
Max. speed mph	75	68	
Transmission Model	Eaton FS4205A	AISIN 450-43LE	
Type	Five-speed direct drive synchromesh 2nd-5th	Four-speed automatic	
Ratios	1st.	8.050	3.018
	2nd.	4.350	1.548
	3rd.	2.450	1.000
	4th.	1.480	0.703
	5th.	1.000	-
	Rev.	8.050	2.678
Rear axle gear ratios	3.730	5.860	

Option ratio is combined with 17,600 lbs. GVW

## ENGINE

Model	HINO J05D-TA - 2004EPA Certified
Type	Diesel 4-cycle, 4-cylinder in-line, water-cooled
Combustion system	Direct injection type
Max. output (SAE Gross)	175HP at 2,700 rpm
Max. torque (SAE Gross)	347 lb.-ft. at 1,600 rpm
Bore and stroke	4.41 x 4.72 in.
Piston displacement	5 L
Fuel system	Common rail
Governor	Electronically controlled
Intake system	Turbocharged and intercooled
Air cleaner	Paper filter type ("DONALDSON")
Fan clutch	Bimetal thermostat sensor, regulates fan speed



A TOYOTA Group Company

WWW.HINO.COM [T]248.648 6400

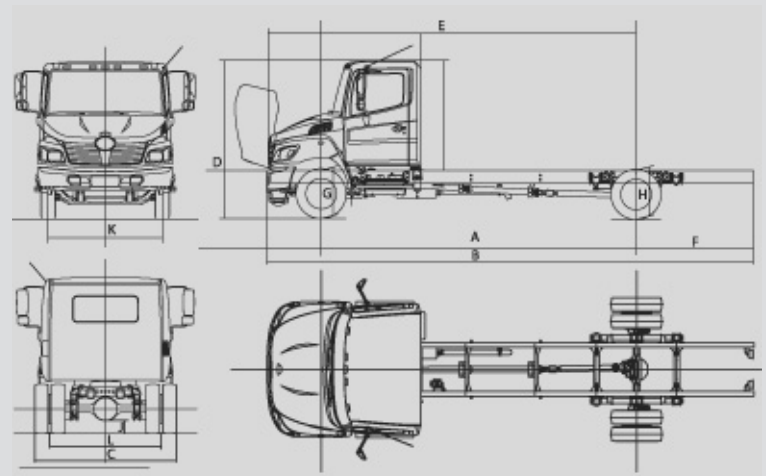

SEE THE 185 IN ACTION AT WWW.HINO.COM

# HINO 185

4 x 2 CONVENTIONAL, GVW 18,000 lbs. BBC 98"  
ENGINE MODEL J05D-TA (Turbo Intercooled) Spec. No. SS-NC004

## WEIGHT CAPACITIES

Front axle	lbs.	6,000
Rear axle	lbs.	13,000
Front spring	lbs.	6,000
Rear spring	lbs.	13,000

## LIQUID CAPACITIES

Fuel tank	gal./US	35
Cooling system	gal./US	5 : Eaton FS4205A 5 : AISIN 450-43LE

## AXLE / SUSPENSION

Front axle	MFS-6 series reversed Elliot, "I" beam
Front spring	Taper-leaf springs shock absorbers
Rear axle	RS13-120 series full-floating, single reduction single-speed by hypoid gears
Rear spring	Semi-elliptic main and auxiliary helper-leaf spring

## FRAME

Ladder type	Straight C channel	
Width	in.	34
Yield strength	PSI	80,000
Resisting bending moment (one side) in_lbs.	655,100 no reinforcement	

## STEERING

Type	Telescopic and tilt steering column TRW-TAS40
------	--

## BRAKES

Service brake	Hydraulic system with disc brake for front and rear wheels , with automatic adjustment
Disc diameter x lining width x thickness in.	Front; 12.756 x 17.05 x 0.61 Rear; 15.375 x 18.96 x 0.74
Control	Hydraulic dual circuit with Antilock Brake System(ABS)
Parking brake	Mechanical, internal expanding acting on transmission output shaft
Drum diameter in.	9 : FS4205A 10 : Aisin 450-43LE

## CLUTCH

Type	Dry single plate with damper springs EATON-SPICER AR350 series
Facing material	Cerametallic
Facing outside diameter in.	12.00
Control	Hydraulic

## WHEELS / TIRES

6 Wheels (Steel)	19.5 x 6.00 8-stud disc.
6 Tires	225/70R19.5(F) - Bridgestone R250F/M729

## CAB EQUIPMENT

Cab construction	All steel welded
Seating	Three man
Driver's seat	Adjustable, reclining, vinyl covered seat, coil suspension
Passenger's seat	Bench type, vinyl, 2 passenger
Seat belts	3-point type (driver and passenger), one 2-point type (center)
Air conditioner	Denso 134
Heater/Defroster	18,357 BTU/h
Mirrors outside rearview	Four, 1 flat and 1 convex at each side
Sun visors	Two
Windshield	Laminated
Windshield wipers	Dual electric, 2-speed and intermittent
Cruise control	Equipped

## DASH INSTRUMENTATION

Meters and gauges ft. lb. system
Speedometer-mph (km/h)
Odometer (mile)
Fuel gauge
Coolant temperature gauge
Engine tachometer
Warning and buzzers
Oil pressure warning lamp and buzzer
Brake pressure warning lamp and buzzer
Coolant level warning lamp and buzzer
Battery charging warning lamp
High beam indicator lamp
Turn signal pilot lamp
Parking brake warning lamp
Engine control system warning lamp
ABS warning lamp

## ELECTRICAL EQUIPMENT

Batteries	Two, parallel connection, each 12 V
Capacity	1200 CCA
Alternator	12 V, 100 A, brush (Delco)
Starter	12 V
Audio	AM/FM radio with CD player
Headlamps	Integrated with turn signal and hazard lamp
Daytime running lamps	
Stop/Tail lamps	
Back-up lamps	
Side-flasher lamp	
Dome lamp	
Front side marker lamps	
Clearance lamps (front)	

## CHASSIS EQUIPMENT

Fuel pre-filter	Pre-filter (dust) and sedimenter (water)
Reflectors	Two rear, two front side
Hook	One at front

## Options

_ Cold weather package (Block heater, heated mirror, glow plugs and heated pre-filter/sediment)
_ Cloth seats
_ Single passenger's seat - Adjustable reclining
_ Alternator - 12 V, 105 A, brushless (Denso)
_ Front spring; with stabilizer
_ Rear spring; with dual acting shock absorbers
_ 4 inch extended, Front bumper (Black)
_ Power windows
_ Battery GR27 x 3
_ Engine block heater
_ Heated mirrors

**NOTE :** All specifications of the products are within normal manufacturing allowances and tolerances. HINO MOTORS SALES U.S.A.,INC. reserves the right to alter specifications at any time without previous notice. Some optional items of equipment may require extra time due to the need for their adaptation on the product line.